

Fingerprint Based Door Access System

^[1] Shaikh Mohd Adil, ^[2] Ansari Umair, ^[3] Usama Shaikh, ^[4] Tushar Kamble, ^[5] Vijaya Sagvekar
^{[1][2][3][4]} Student Member, PVPPCOE SION
^[5] Asst.Professor, PVPPCOE, SION

Abstract: - Security has been playing a key role in many of our places like offices, institutions, libraries, laboratories etc. in order to keep our data confidentially so that no other unauthorized person could have an access on them. Nowadays, at every point of time, we need security systems for protection of valuable data and even money. This paper presents a fingerprint based door opening system which provides security which can be used for many banks, institutes and various organizations etc.... There are other methods of verifying authentication through password, RFID but this method is most efficient and reliable. To provide perfect security to the bank lockers and to make the work easier, this project is taking help of two different technologies viz. EMBEDDED SYSTEMS and BIOMETRICS. Unauthorized access is prohibited by designing a lock that stores the fingerprints of one or more authorized users. Fingerprint is sensed by sensor and is validated for authentication. If the fingerprint matches, the door will be opened automatically otherwise the buzzer connected to an audio amplifier will be activated so that the people near the surroundings will get an alert.

Keywords:- Biometrics, Fingerprint, Authentication, image Processing.

I. INTRODUCTION

Security is of primary concern and in this busy, competitive world, human cannot find ways to provide security to his confidential belongings manually. Instead, he finds an alternative which can provide a full fledged security as well as atomized. In the ubiquitous network society, where individuals can easily access their information anytime and anywhere, people are also faced with the risk that others can easily access the same information anytime and anywhere. Because of this risk, personal identification technology, which can distinguish between registered legitimate users and imposters, is now generating interest. Generally passwords, identification cards and PIN verification techniques are being used but the disadvantage is that the passwords could be hacked and a card may be stolen or lost. The most secured system is fingerprint recognition because a fingerprint of one person never matches the other. Biometrics studies commonly include fingerprint, face, iris, voice, signature, and hand geometry recognition and verification. Many other modalities are in various stages of development and assessment. Among these available biometric traits fingerprint proves to be one of the best traits providing good mismatch ratio, high accurate in terms of security and also reliable.

II. RELATED WORK

When fingerprint module is interfaced to the microcontroller, it will be in user mode. In this mode, stored images will be verified with the scanned images. When

coming to our application the images of the person's fingerprint that are authorized to open the locker door will be stored in the module with a unique id. To prove that the persons are authorized to open the locker door they need to scan their fingerprint images. The scanner is interfaced to 8051 microcontroller; this controller will be controlling the scanning process. Immediately the locker will be opened[1]. After the work has been completed if key is pressed again with help of keypad the locker door will be closed again. If an unauthorized person tries to scan his fingerprint image then an indication will be given by a buzzer which is interfaced to the controller and also if wrong password is entered by the user again indication will be given by the buzzer. The current user instead of him/her can make a new person as the user of the same locker by new registration process and the old user's fingerprint image will be deleted. Option for changing the password is also available[2]. Our proposed system overcomes all the security problems in existing system and provides high security and efficiency. This is a perfect/optimal solution for saving/protecting one from the hassle of stolen/lost key or an unauthorized entry. Fingerprint is a boon solution for these problems which provides high level of recognition accuracy. The skin on our palms and soles exhibits a flow like pattern of ridges called friction ridges. The pattern of friction ridges on each finger is unique and immutable. This makes fingerprint a unique identification for everyone. Fingerprint door lock incorporates the proven technology. Fingerprint scanner scans the fingerprints of users and used for ensuring authentication. Fingerprint scanning is more accurate and cost effective method and duplication is virtually impossible. A Fingerprint recognition system can

International Journal of Engineering Research in Computer Science and Engineering (IJERCSE)

Vol 5, Issue 3, March 2018

easily perform verification. In verification, the system compares an input fingerprint to the enrolled fingerprint of a specific user to determine if they are from the same finger. Now the security of our home/office is literally in our hands or rather on our fingertips[3].

2.1 Conclusion & Future Scope

In today's technologically advanced world, autonomous systems are gaining rapid popularity so the advancement in latest technology is continuously and rapidly made on different latest automatic door lock security systems. The need for an advanced door lock security systems using new technologies is increases day by day as security become a very important or serious issue for everybody. Due to the recent trends in various methods of security for home, buildings, companies' vehicles etc, there is no need to worry about this security any longer, as automatic security systems are here to deal with it. This paper tries to focus all recent door lock security systems in a comprehensive way A step by step approach in designing the microcontroller based system for securing the transactions of the user and providing the security for the locker system and even more for the PASSPORT verification using a finger print scanner has been followed. The result obtained in providing the security is quite reliable in all the three modes. The system has successfully overcome some of the aspects existing with the present technologies, by the use of finger print Biometric as the authentication Technology.

REFERENCES

- [1] Signals, Systems and Computers, 2004 Conference Record of the Thirty-Eighth Asilomar Conference on Publication 7-Nov-2004 Volume: 1, on page(s): 577-581 Vol.1.
- [2] International Journal of Advanced Research in Computer Science and Software Engineering, Volume 2, Issue 10, October 2012.
- [3] International Journals of Biometric and Bioinformatics, Volume (3): Issue (1).
- [4] Mukesh Kumar Thakur, Ravi Shankar Kumar, Mohit Kumar, Raju Kumar "Wireless Fingerprint Based Security System using Zigbee" , International Journal of Inventive Engineering and Sciences (IJIES) ISSN: 2319-9598, Volume-1, Issue-5, April 2013.
- [5] Mary Lourde R and Dushyant Khosla, "Fingerprint Identification in Biometric Security Systems", International Journal of Computer and Electrical Engineering, Vol. 2,

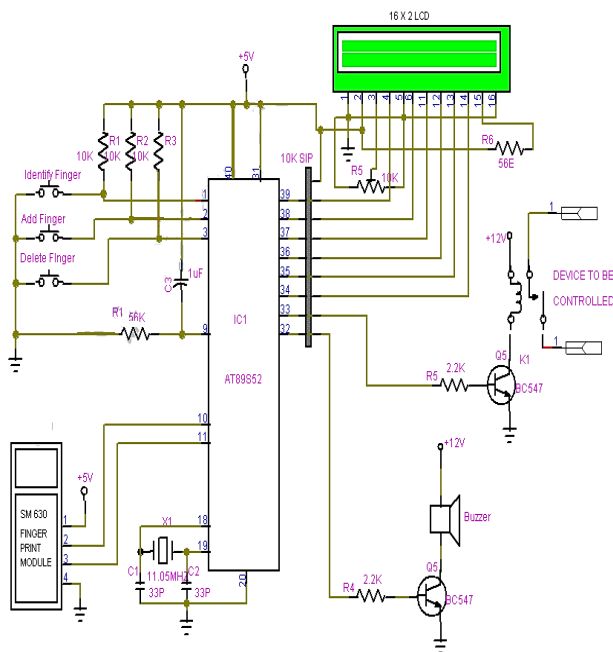

Fig1. Block diagram of Fingerprint based Door Access System